



ORIENT

Photo coupler

Product Data Sheet

Part Number: OR-152

Customer: _____

Date: _____

SHENZHEN ORIENT COMPONENTS CO., LTD

Block A 3rd Floor No.4 Building, Tian'an Cyber Park, Huangge Rd, LongGang Dist, Shenzhen, GD

TEL: 0755-29681816

FAX: 0755-29681200

www.orient-opto.com

1. Features

- (1) Buffer logic type (Totem pole output)
- (2) Output peak current: ±2.5 A (max)
- (3) Supply current: 3 mA (max)
- (4) Supply voltage: 10 to 30 V
- (5) Threshold input current: 7.5 mA(max)
- (6) Propagation delay time: tpHL = 190 ns (max), tpLH = 170 ns (max)
- (7) Common-mode transient immunity: ±20 kV/μs (min)
- (8) Isolation voltage: 3750 Vrms (min)
- (9) Available in Stretched SO-5 package
- (10) Industrial temperature range: -40° C to 100° C
- (11) Safety approval
 - UL approved(No.E323844)
 - VDE approved(No.40029733)
 - CQC approved (No.CQC22001345200)
- (12) In compliance with RoHS, REACH standard
- (13) MSL Level 1



2. Description

The OR-152 is a photocopier in a SO6 package that consists of a GaAlAs infrared light-emitting diode(LED) optically coupled to an integrated high-gain, high-speed photodetector IC chip.

3. Application Range

- (1) Plasma Display Panels (PDPs)
- (2) Transistor Inverters
- (3) MOSFET Gate Drivers
- (4) IGBT Gate Drivers

4. Functional Diagram

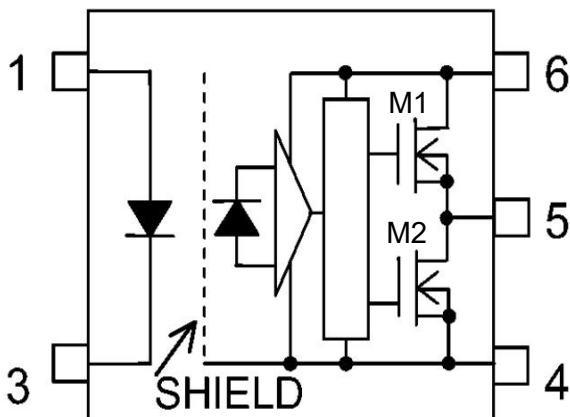

Truth Table				
Input	LED	M1	M2	Output
H	ON	ON	OFF	H
L	OFF	OFF	ON	L

- 1: Anode
- 3: Cathode
- 4: GND
- 5: VO(Output)
- 6: VCC

Note: A 0.1-μF bypass capacitor must be connected between pin 6 and pin 4

5. Absolute Maximum Ratings (Ta=25°C)

Parameter		Symbol	Rated Value	Unit
Input	Average Forward Input Current	I_F	20	mA
	Peak transient input forward current	I_{FPT}	1	A
	Reverse Input Voltage	V_R	5	V
	Input power dissipation	P_D	40	mW
Output	“High” Peak Output Current	$I_{OH(PEAK)}$	2.5	A
	“Low” Peak Output Current	$I_{OL(PEAK)}$	2.5	A
	Output Collector Power Dissipation	P_O	260	mW
Supply Voltage		V_{CC}	35	V
Output Voltage		V_O	35	V
Insulation Voltage		V_{ISO}	3750	V _{rms}
Working Temperature		T_{opr}	-40 ~ + 100	°C
Storage Temperature		T_{stg}	-55 ~ + 125	
*2 Soldering Temperature		T_{sol}	260	

*1. Room temperature = 25 °C. Exceeding the maximum absolute rating can permanently damage the device. Working long hours at the maximum absolute rating can affect reliability.

*2. soldering time is 10 seconds.

6. Electrical Optical Characteristics at Ta=25°C

Parameter	Symbol	Min.	Typ.	Max.	Units	Test Conditions
Peak high-level output current	I _{OPH}	—	-2.1	-1.0	A	I _F = 10 mA, V _{CC} = 15 V, V ₆₋₅ = 4 V
		—	-3.3	-2.0		I _F = 10 mA, V _{CC} = 15 V, V ₆₋₅ = 10 V
Peak low-level output current	I _{OPL}	1.0	2.2	—	A	I _F = 0 mA, V _{CC} = 15 V, V ₅₋₄ = 2 V
		2.0	3.4	—		I _F = 0 mA, V _{CC} = 15 V, V ₅₋₄ = 10 V
High Level Output Voltage	V _{OH}	6.0	8.6	—	V	I _F = 10 mA, V _{CC} = 10 V, I _O = -100 mA
Low Level Output Voltage	V _{OL}	—	0.1	1.0	V	V _F = 0.8 V, V _{CC} = 10 V, I _O = 100 mA
High Level Supply Current	I _{CCH}	—	1.8	3.0	mA	I _F = 10 mA, V _{CC} = 10 to 30 V, V _O = Open
Low Level Supply Current	I _{CCL}	—	1.7	3.0	mA	I _F = 0 mA, V _{CC} = 10 to 30 V, V _O = Open
Threshold Input Current Low to High	I _{FLH}	—	1.4	7.5	mA	V _{CC} = 15 V, V _O > 1 V
Threshold Input Voltage High to Low	V _{FHL}	0.8	1.48	—	V	V _{CC} = 15 V, V _O < 1 V
Supply voltage	V _{CC}	10	—	30	V	
U _{VLO} threshold voltage	V _{UVLO+}	7.5	8.5	9.5	V	I _F = 5 mA, V _O > 2.5 V
	V _{UVLO-}	7.5	8.2	9.5	V	I _F = 5 mA, V _O < 2.5 V
U _{VLO} hysteresis	UVLO _{HYS}	—	0.3	—	V	I _F = 5 mA, V _O > 2.5 V
Input Forward Voltage	V _F	1.4	1.55	1.8	V	I _F = 10 mA
Temperature Coefficient of Forward Voltage	ΔV _F /ΔT _A	—	-1.7	—	mV/°C	I _F = 10 mA
Input Reverse Breakdown Voltage	B _{VR}	5	—	—	V	I _R = 100 μA
Input Capacitance	C _{IN}	—	70	—	pF	f = 1 MHz, V _F = 0V

Note: All typical values are at T_a = 25°C.

7. Switching Characteristics

Characteristics	Symbol	Test Condition	Min	Typ.	Max	Unit
Propagation delay time (L/H)	t_{pLH}	$I_F = 0 \rightarrow 10 \text{ mA}, V_{CC} = 30 \text{ V},$ $R_g = 20 \Omega, C_g = 10 \text{ nF}, T_a = 25^\circ\text{C}$	—	92	145	ns
Propagation delay time (H/L)	t_{pHL}	$I_F = 10 \rightarrow 0 \text{ mA}, V_{CC} = 30 \text{ V},$ $R_g = 20 \Omega, C_g = 10 \text{ nF}, T_a = 25^\circ\text{C}$	—	105	165	
Propagation delay time (L/H)	t_{pLH}	$I_F = 0 \rightarrow 10 \text{ mA}, V_{CC} = 30 \text{ V},$ $R_g = 20 \Omega, C_g = 10 \text{ nF}$	50	92	170	
Propagation delay time (H/L)	t_{pHL}	$I_F = 10 \rightarrow 0 \text{ mA}, V_{CC} = 30 \text{ V},$ $R_g = 20 \Omega, C_g = 10 \text{ nF}$	50	105	190	
Propagation delay skew (device to device)	t_{psk}	$I_F = 0 \leftrightarrow 10 \text{ mA}, V_{CC} = 30 \text{ V},$ $R_g = 20 \Omega, C_g = 10 \text{ nF}$	-85	—	85	
Pulse width distortion	$ t_{pHL} - t_{pLH} $	$I_F = 0 \leftrightarrow 10 \text{ mA}, V_{CC} = 30 \text{ V},$ $R_g = 20 \Omega, C_g = 10 \text{ nF}$	—	13	50	
Rise time	t_r	$I_F = 0 \rightarrow 10 \text{ mA}, V_{CC} = 30 \text{ V},$ $R_g = 20 \Omega, C_g = 10 \text{ nF}$	—	16	—	
Fall time	t_f	$I_F = 10 \rightarrow 0 \text{ mA}, V_{CC} = 30 \text{ V},$ $R_g = 20 \Omega, C_g = 10 \text{ nF}$	—	20	—	
Common-mode transient immunity at output high	$ CM_H $	$V_{CM} = 1000 \text{ Vp-p}, I_F = 10 \text{ mA},$ $V_{CC} = 30 \text{ V}, T_a = 25^\circ\text{C}, V_{O(\min)} = 26 \text{ V}$	± 20	—	—	kV/ μs
Common-mode transient immunity at output low	$ CM_L $	$V_{CM} = 1000 \text{ Vp-p}, I_F = 0 \text{ mA},$ $V_{CC} = 30 \text{ V}, T_a = 25^\circ\text{C}, V_{O(\max)} = 1 \text{ V}$	± 20	—	—	

Note: All typical values are at $T_a = 25^\circ\text{C}$.

1. Input signal ($f = 125 \text{ kHz}$, duty = 50%, $t_r = t_f = 5 \text{ ns}$ or less). CL is approximately 15 pF which includes probe and stray wiring capacitance.

2. CM_H is the maximum rate of rise of the common mode voltage that can be sustained with the output voltage in the logic high state ($V_O > 26 \text{ V}$).

3. CM_L is the maximum rate of fall of the common mode voltage that can be sustained with the output voltage in the logic low state ($V_O < 1 \text{ V}$).

4. The propagation delay skew, t_{psk} , is equal to the magnitude of the worst-case difference in t_{pHL} and/or t_{pLH} that will be seen between units at the same given conditions (supply voltage, input current, temperature, etc).



8. Order Information

Part Number

OR-152-W-Y-Z

Note

W = Tape and reel option. (TP or TP1).

Y = 'V' code for VDE safety (This options is not necessary).

Z = 'G' code for Halogen free.

* VDE Code can be selected.

Option	Description	Packing quantity
S(TP)	Surface mount lead form (low profile) + TP tape & reel option	3000 units per reel
S(TP1)	Surface mount lead form (low profile) + TP1 tape & reel option	3000 units per reel

9. Naming Rule

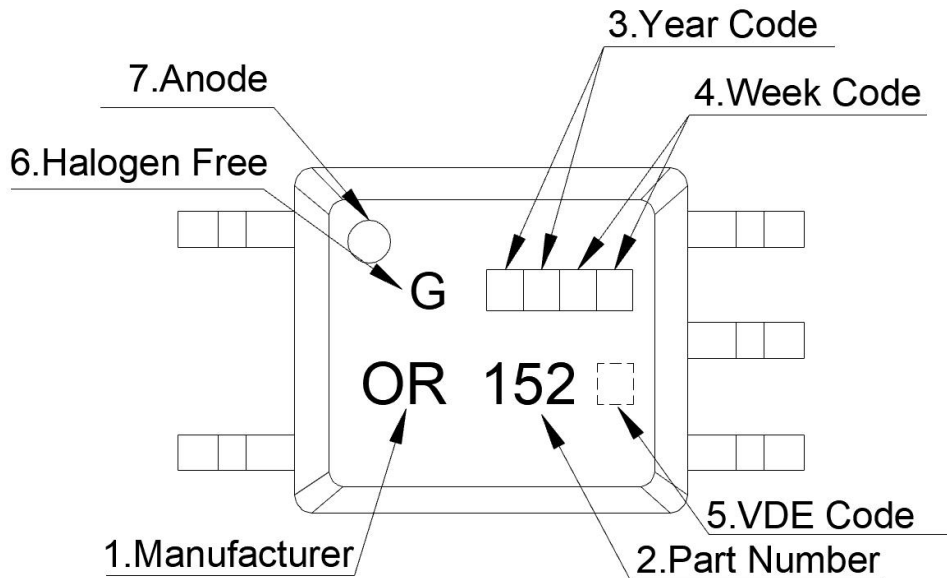

1. Manufacturer : ORIENT.
2. Part Number : 152.
3. Year Code [][] : '21' means '2021' and so on.
4. Week Code [][]: 01 means the first week, 02 means the second week and so on.
5. VDE Code [] (Optional)
6. Halogen free code.
7. Anode.

* VDE Mark can be selected.

1. Outer Dimension

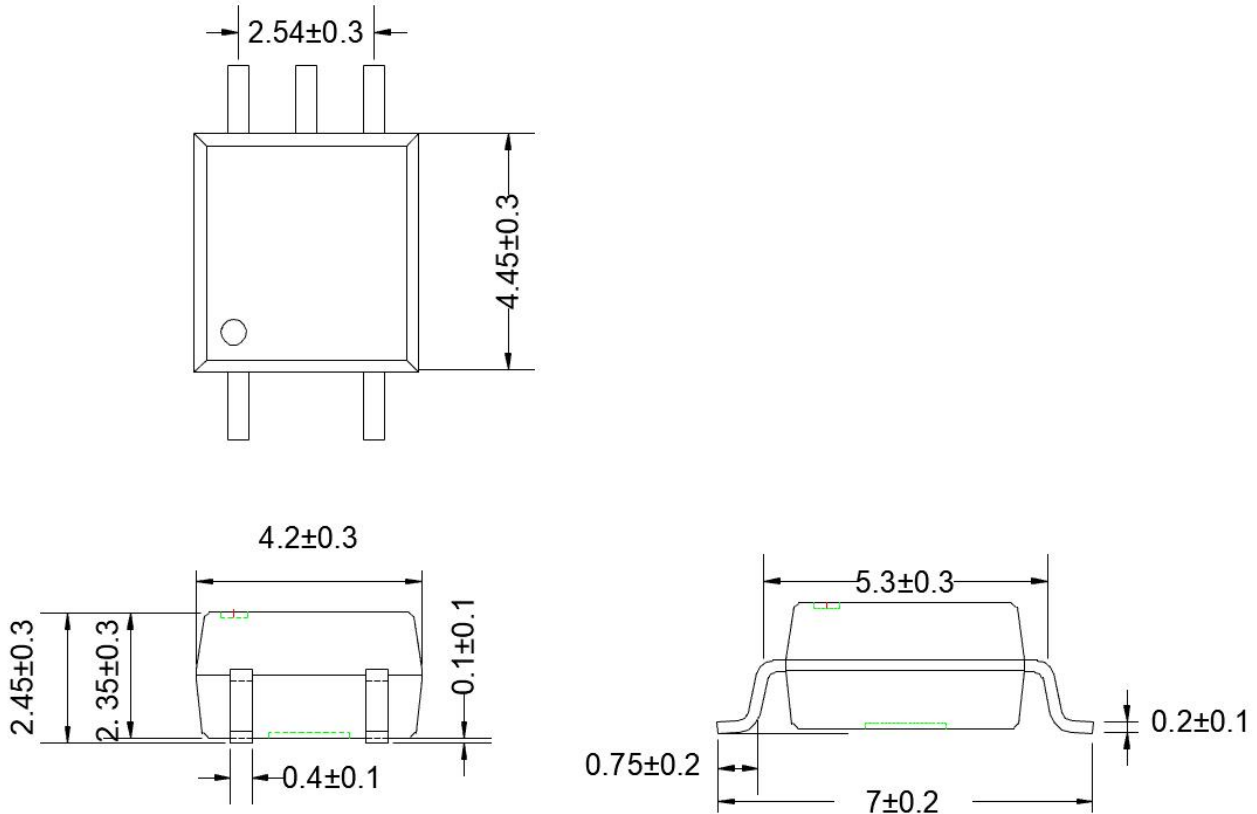

2. Recommended Foot Print Patterns (Mount Pad)

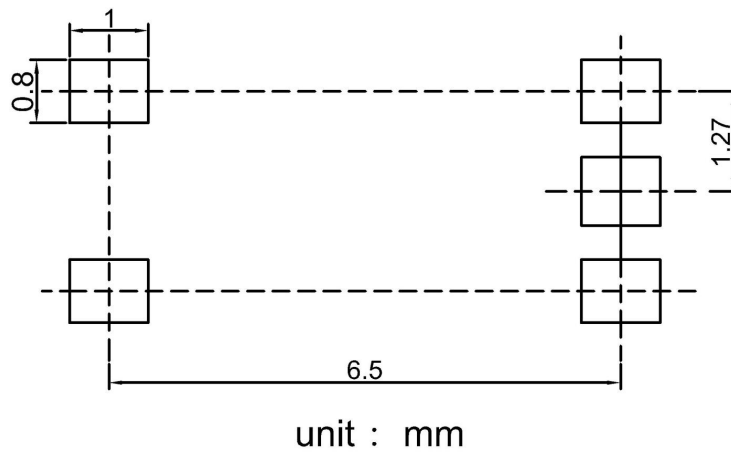

3. Taping Dimensions

(1) OR-152-TP

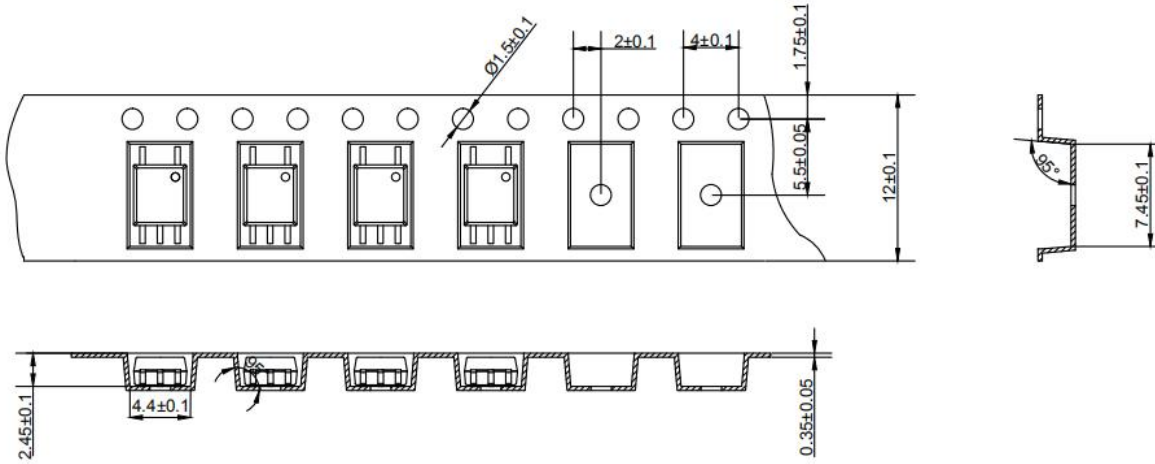

(2) OR-152-TP1

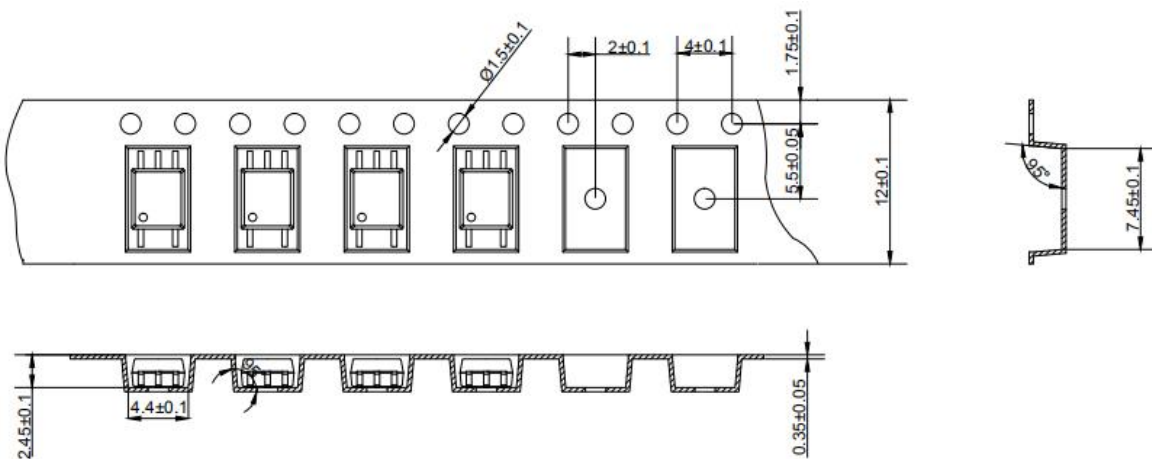

Description	Symbol	Dimension in mm(inch)
Tape wide	W	12 ± 0.3 (0.472)
Pitch of sprocket holes	P0	4 ± 0.1 (0.157)
Distance of compartment	F	5.5 ± 0.1 (0.217)
	P2	2 ± 0.1 (0.079)
Distance of compartment to compartment	P1	8 ± 0.1 (0.315)

Encapsulation type	TP/TP1
amount (pcs)	3000

4. Package Dimension

(1) package dimension

Packing Information	
Packing type	Reel type
Tape Width	12mm
Qty per Reel	3,000pcs
Small box (inner) Dimension	345*345*45mm
Large box (Outer) Dimension	480x360x360mm
Max qty per small box	6,000pcs
Max qty per large box	60,000pcs

(2) Packing Label Sample



Note:

1. Material Code :Product ID.
2. P/N :Contents with "Order Information" in the specification.
3. Lot No. :Product data.
4. D/C :Product weeks.
5. Quantity :Packaging quantity.

10. Temperature Profile Of Soldering

(1).IR Reflow soldering (JEDEC-STD-020C compliant)

One time soldering reflow is recommended within the condition of temperature and time profile shown below. Do not solder more than three times.

Profile item	Conditions
Preheat - Temperature Min (T Smin) - Temperature Max (T Smax) - Time (min to max) (ts)	150°C 200°C 90±30 sec
Soldering zone - Temperature (TL) - Time (t L)	217°C 60 sec
Peak Temperature	260°C
Peak Temperature time	20 sec
Ramp-up rate	3°C / sec max.
Ramp-down rate from peak temperature	3~6°C / sec
Reflow times	≤3

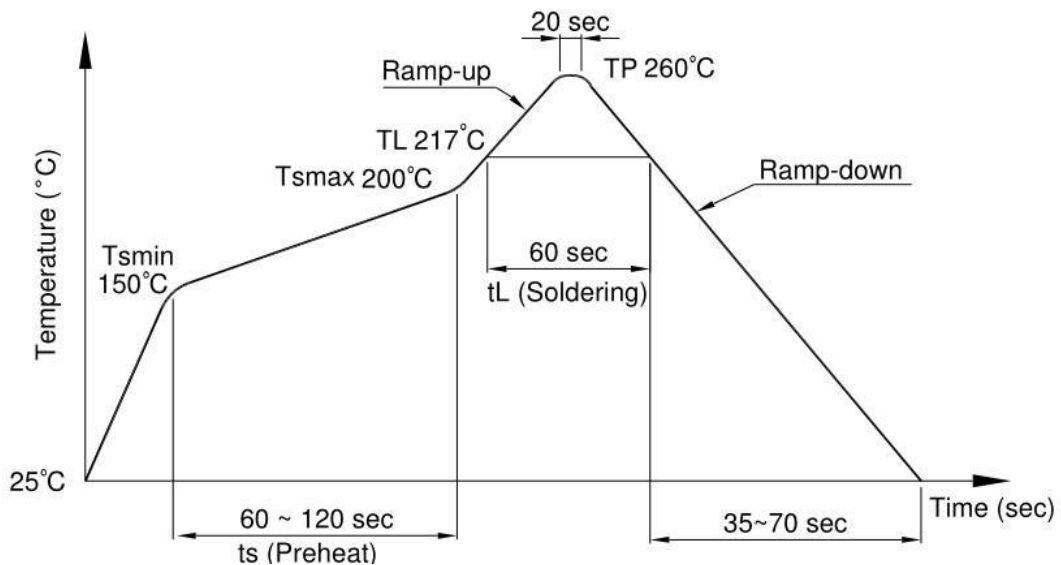

(3) .Wave soldering (JEDEC22A111 compliant)

One time soldering is recommended within the condition of temperature.

Temperature	260+0/-5°C
Time	10 sec
Preheat temperature	5 to 140°C
Preheat time	30 to 80 sec

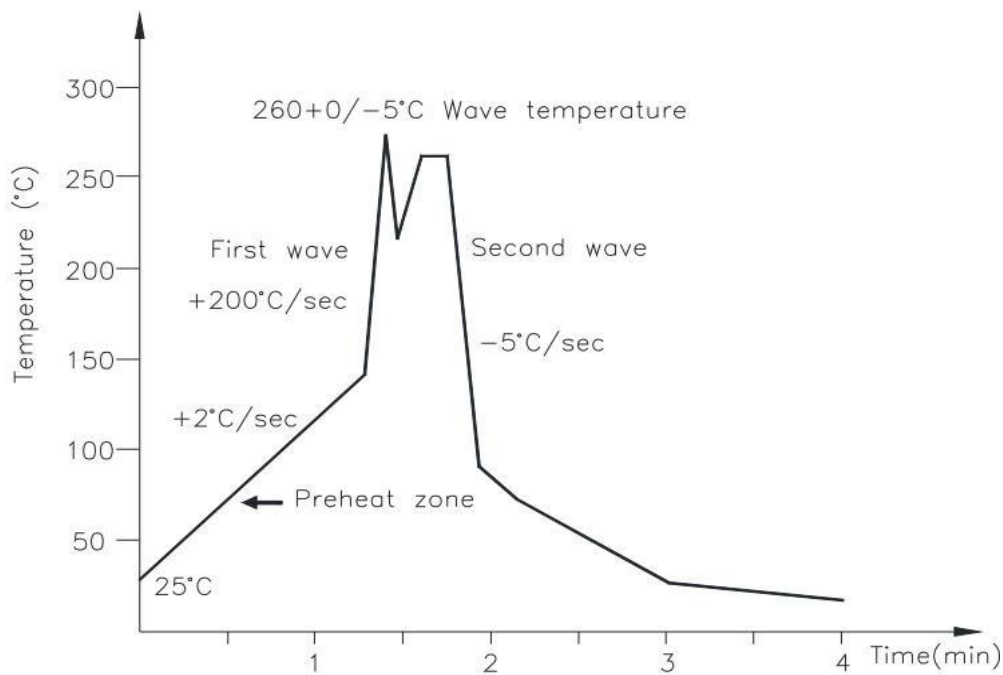

(3).Hand soldering by soldering iron

Allow single lead soldering in every single process. One time soldering is recommended.

Temperature	380+0/-5°C
Time	3 sec max

11. CHARACTERISTICS CURVES (TYPICAL PERFORMANCE)

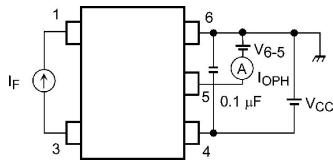

Fig. 12.1.1 IOPH Test Circuit

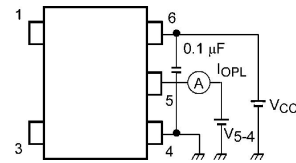
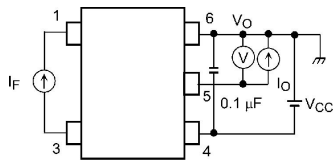

Fig. 12.1.2 IOPL Test Circuit



*V_{OH} = V_{CC}-V_O
Fig. 12.1.3 V_{OH} Test Circuit

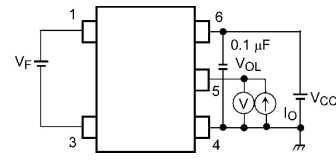

Fig. 12.1.4 V_{OL} Test Circuit

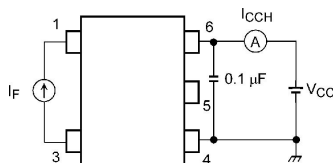

Fig. 12.1.5 I_{CCH} Test Circuit

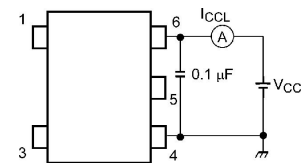
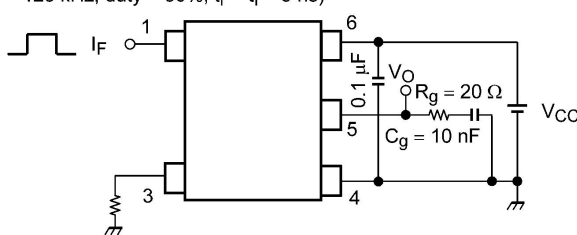

Fig. 12.1.6 I_{CCL} Test Circuit

I_F = 10 mA (P.G.)

(f = 125 kHz, duty = 50%, t_r = t_f = 5 ns)



P.G.: Pulse generator

Fig. 12.1.7 Switching Time Test Circuit and Waveform

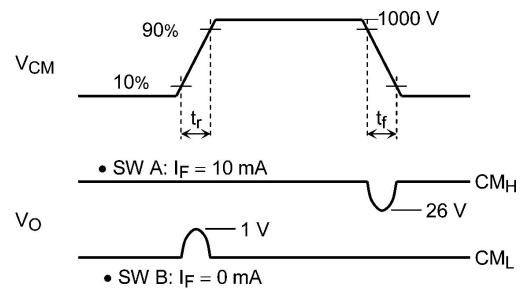
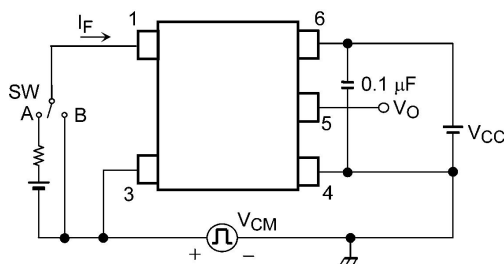

$$CM_L = \frac{800 \text{ V}}{t_r (\mu\text{s})} \quad CM_H = -\frac{800 \text{ V}}{t_r (\mu\text{s})}$$

Fig. 12.1.8 Common-Mode Transient Immunity Test Circuit and Waveform