



# ORIENT

## Photo coupler

### Product Data Sheet

MPN: ORPC-817 series of GK

Customer: \_\_\_\_\_

Date: \_\_\_\_\_

#### SHENZHEN ORIENT COMPONENTS CO., LTD

Block A3rd Floor No.4 Building, Tian'an Cyber Park, Huangge Rd, LongGang Dist, Shenzhen, GD

TEL: 0755-29681817  
FAX: 0755-29681200  
[www.orient-opto.com](http://www.orient-opto.com)

**Preliminary**

This datasheet is a preliminary design specification, and the formal specifications are subject to the recognition letter with jointly signed

**1. Features**

- (1) Current transfer ratio ( CTR : MIN. 50% at  $I_F = 5\text{mA}$ ,  $V_{CE} = 5\text{V}$  )
- (2) High input-output isolation voltage (  $V_{iso} = 5,000\text{Vrms}$  )
- (3) Response time (  $t_r$  : TYP.  $2.9\mu\text{s}$  at  $V_{CE} = 2\text{V}$ ,  $I_C = 2\text{mA}$ ,  $R_L = 100\Omega$  )
- (4) Operating Temperature  $-55\text{ }^\circ\text{C}$  to  $125\text{ }^\circ\text{C}$
- (5) ESD pass HBM 8000V/MM 2000V
- (6) Safety approval
  - UL approved (No.E323844)
  - VDE approved(No.40029733)
  - CQC approved (No.CQC09001029446)
  - CE approved (No.AC/0431008)
  - State Grid approved (No.SGCM013420240085 )
- (7) In compliance with RoHS, REACH standards
- (8) MSL Class I



**2. Description**

- (1) ORPC-817-(GK) photo coupler consist of one piece of GaAs emitter and one piece of NPN transistor.
- (2) Packaged in a 4-pin DIP package and available in wide-lead spacing and SMD option.

**3. Applications**

- (1) Switching power supply
- (2) Ammeter
- (3) Computer
- (4) Instrumental application, measurement machine
- (5) Signal transforming systems
- (6) Imbursement equipments, duplicating machine, automat
- (7) Family-use electric equipments, such as fans

**4. Functional Diagram**

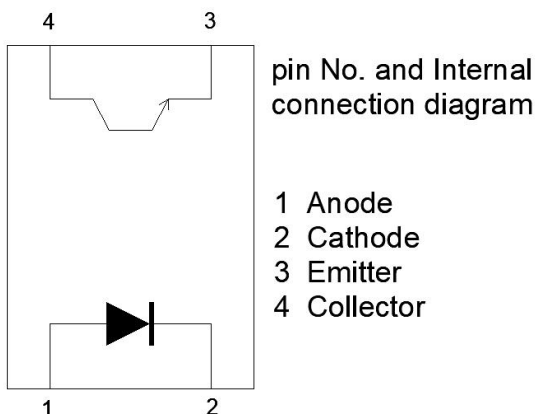

5. Absolute Maximum Ratings at Ta=25°C

Parameter		Symbol	Rated Value	Unit
Input	Forward Current	$I_F$	60	mA
	Peak forward current (100µs pulse, 100Hz frequency)	$I_{FP}$	1	A
	Reverse Voltage	$V_R$	6	V
	Input Power	$P_I$	70	mW
Output	Collector and emitter Voltage	$V_{CEO}$	80	V
	Emitter and collector Voltage	$V_{ECO}$	7	
	Collector Current	$I_C$	50	mA
	Output Power	$P_O$	150	mW
Total Consume Power		$P_{tot}$	200	mW
*1 Isolation Voltage		$V_{iso}$	5000	Vrms
Maximum transient isolation voltage (Insulating oil test)		$V_{IOTM}$	8000	$V_{peak}$
Maximum repetitive peak isolation voltage		$V_{IORM}$	850	$V_{peak}$
Operation Temperature		$T_{opr}$	-55 to + 125	°C
Storage Temperature		$T_{stg}$	-55 to + 150	
*2 Soldering Temperature		$T_{sol}$	260	

\*1.AC For 1 Minute, R.H. = 40 ~ 60%

Isolation voltage shall be measured using the following method.

- (1) Short between anode and cathode on the primary side and between collector and emitter on the secondary side.
- (2) The isolation voltage tester with zero-cross circuit shall be used.
- (3) The waveform of applied voltage shall be a sine wave.

\*2. Soldering time is 10 seconds

**6. Electro-Optical Characteristics (Ta=25°C unless specified otherwise)**

Parameter		Symbol	Min	Typ.*	Max	Unit	Condition
<b>Input</b>	Forward Voltage	$V_F$	---	1.2	1.4	V	$I_F=20\text{mA}$
	Reverse Current	$I_R$	---	---	5	$\mu\text{A}$	$V_R=5\text{V}$
	Terminal capacitance	$C_t$	---	20	250	pF	$V=0, f=1\text{MHz}$
<b>Output</b>	Dark Current	$I_{CEO}$	---	---	100	nA	$V_{CE}=20\text{V}$ $I_F=0\text{mA}$
	Collector-Emitter Breakdown Voltage	$BV_{CEO}$	80	---	---	V	$I_C=0.1\text{mA}$ $I_F=0\text{mA}$
	Emitter-Collector Breakdown Voltage	$BV_{ECO}$	7	---	---	V	$I_E=0.1\text{mA}$ $I_F=0\text{mA}$
<b>Transforming Characteristics</b>	*1 Current transfer ratio	CTR	50	---	600	%	$I_F=5\text{mA}$ $V_{CE}=5\text{V}$
	Collector Current	$I_C$	2.5	---	30	mA	$I_F=5\text{mA}$ $V_{CE}=5\text{V}$
	Collector and Emitter Saturation Voltage	$V_{CE(sat)}$	---	0.1	0.2	V	$I_F=20\text{mA}$ $I_C=1\text{mA}$
	Isolation Impedance	$R_{iso}$	$5 \times 10^{10}$	$1 \times 10^{12}$	---	$\Omega$	DC500V 40~60%R.H.
	Floating Capacitance	$C_f$	---	0.4	1.0	pF	$V=0, f=1\text{MHz}$
	Rise Time	$t_r$	---	2.9	10	$\mu\text{s}$	$V_{CC}=2\text{V}$ $I_C=2\text{mA}$ $R_L=100\ \Omega$
	Fall Time	$t_f$	---	4.5	10	$\mu\text{s}$	
	Turn-on Time	$t_{on}$	---	6.3	10	$\mu\text{s}$	
Turn-off Time	$t_{off}$	---	7.1	10	$\mu\text{s}$		

\*1 Current Conversion Ratio =  $I_C / I_F \times 100\%$  , CTR Tolerance:  $\pm 3\%$ .

**7. Rank Table of Current Transfer Ratio**

CTR BIN	Min (%)	Max (%)	Condition
A	80	160	$V_{CE} = 5V / I_F = 5mA, T_a=25^{\circ}C$
	40	100	$V_{CE} = 5V / I_F = 1mA, T_a=25^{\circ}C$
B	130	260	$V_{CE} = 5V / I_F = 5mA, T_a=25^{\circ}C$
	50	150	$V_{CE} = 5V / I_F = 1mA, T_a=25^{\circ}C$
C	200	400	$V_{CE} = 5V / I_F = 5mA, T_a=25^{\circ}C$
	80	300	$V_{CE} = 5V / I_F = 1mA, T_a=25^{\circ}C$
D	300	600	$V_{CE} = 5V / I_F = 5mA, T_a=25^{\circ}C$
	120	400	$V_{CE} = 5V / I_F = 1mA, T_a=25^{\circ}C$

**8. Order Information**

**Part Number**

**ORPC-817XT-V-W-Y-Z-(GK)**

**Note**

X = Lead form option ( M or none)

T = CTR Rank (A, B, C, D, A5, B5, C5...)

V = Tape and reel option (TP,TP1 or none).

W = Lead frame (F:Iron , C:copper)

Y = ‘V’ code for VDE safety (This options is not necessary).

Z = ‘G’ code for Halogen free (Copper for HF only).

GK = Field Code.

\* VDE Code can be selected.

Option	Description	Packing quantity
None	Standard DIP-4	100 units per tube
M	Wide lead bend (0.4 inch spacing)	100 units per tube

## 9. Naming Rule

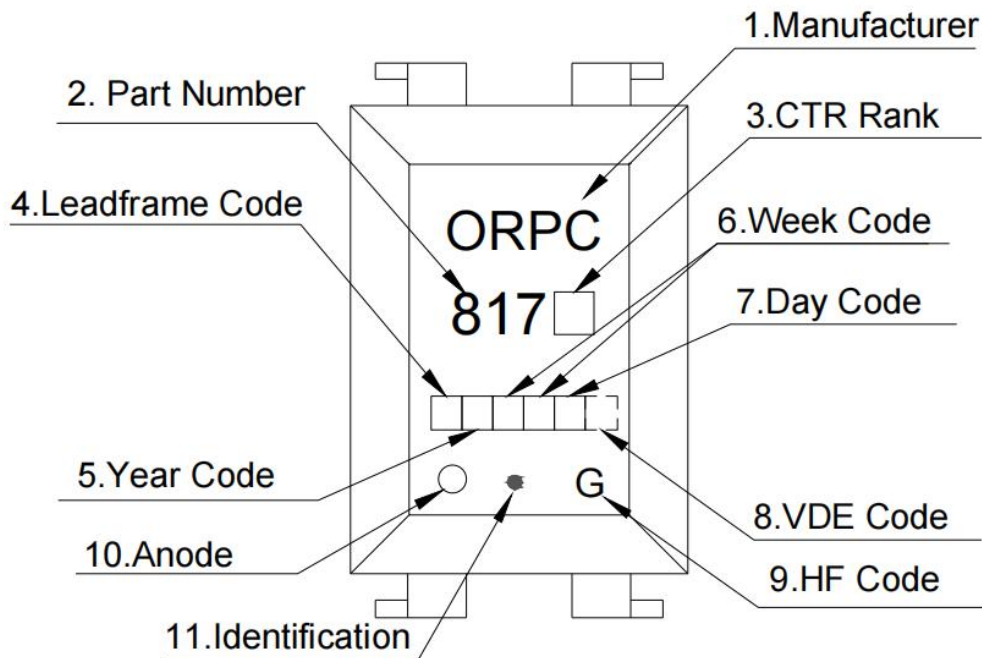

(1) ORIENT PHOTOCOUPLER.

(2) 817 denotes Device Part Number.

(3)  denotes Rank Code.(A,B,C or D)

(4)  denotes Lead Frame Code.

(5)  denotes Year Code.

(6)  denotes Week Code.

(7)  denotes Day Code.

(8)  denotes VDE Code. (Optional)

(9)  denotes HF Code. (Copper for HF only)

(10) Anode.

(11) Identification.

\* VDE Mark can be selected.

10. Package Dimension (Unit: mm)

(1) ORPC-817

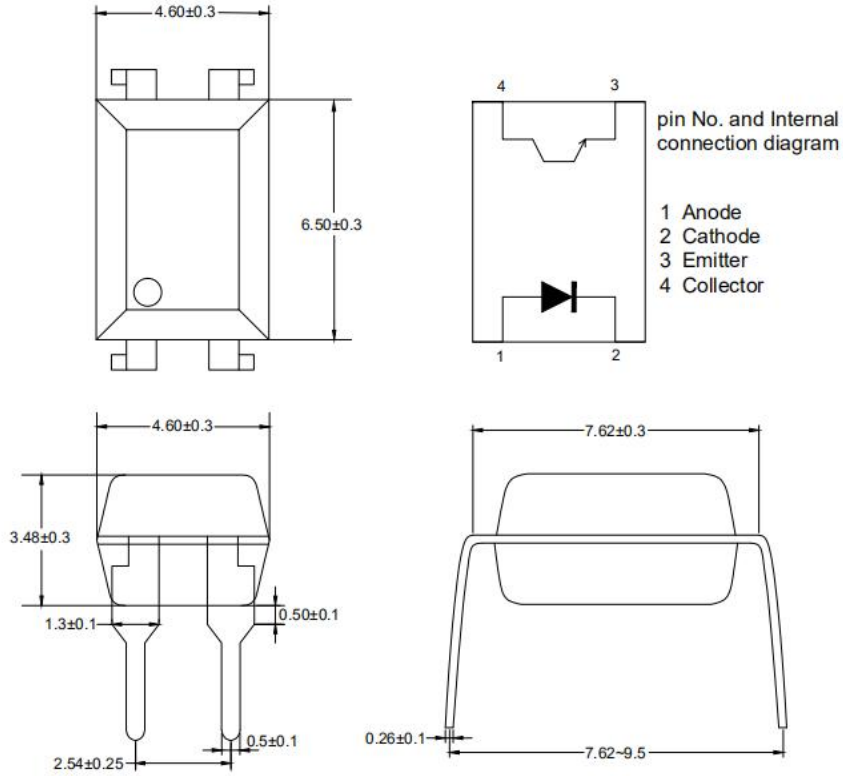

(2) ORPC-817M

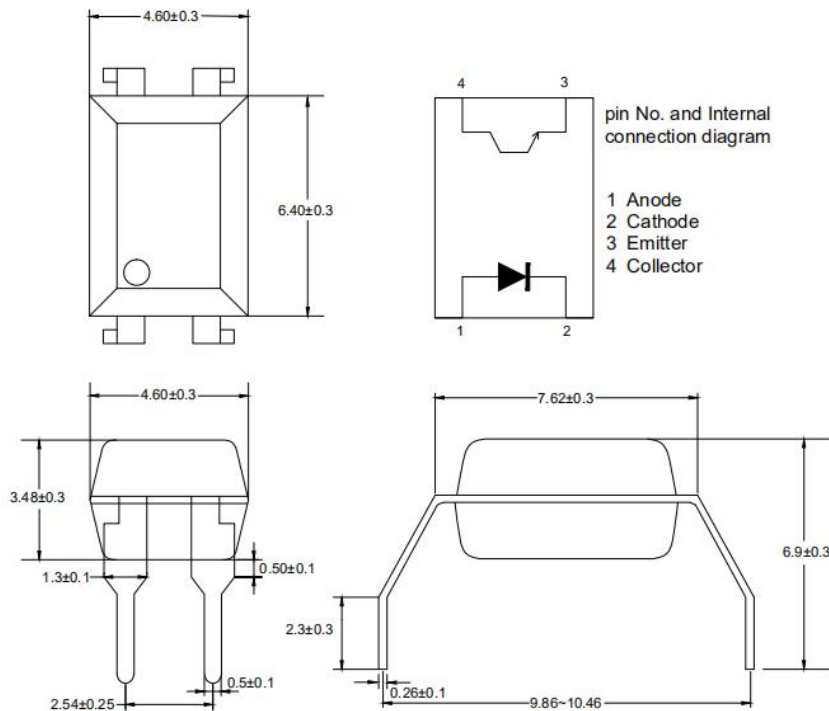

**11. Recommended Foot Print Patterns (Mount Pad) (Unit: mm)**

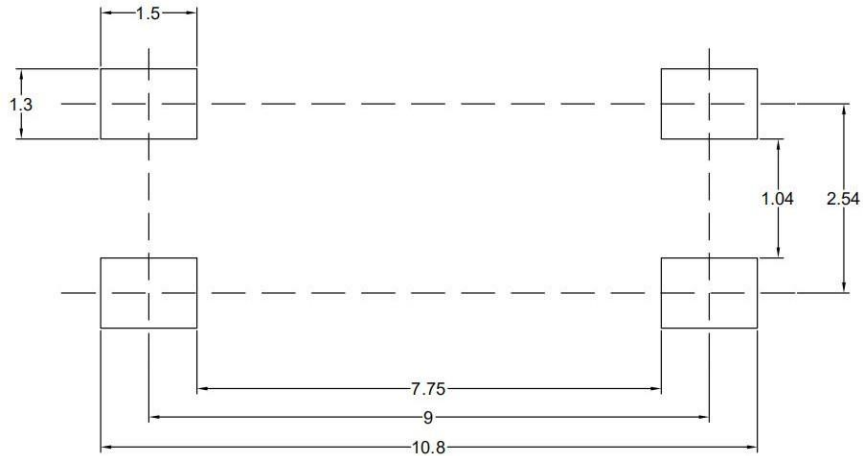

**12. Package Dimension**

Packing Information	
Packing type	Tube
Qty per Tube	100pcs
Small box (Inner) Dimension	525*128*60mm
Large box (Outer) Dimension	545*290*335mm
The Amount per Inner Box	5,000pcs
The Amount per Outer Box	50,000pcs

**(2)Packing Label Sample**

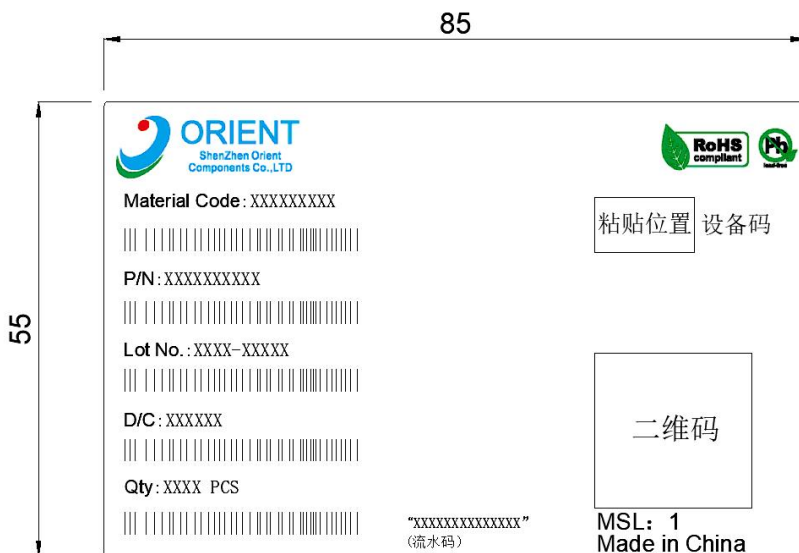

**Note:**

1. Material Code :Product ID.
2. P/N :Contents with "Order Information" in the specification.
3. Lot No. :Product data.
4. D/C :Product weeks.
5. Quantity :Packaging quantity.

### 13. Temperature Profile Of Soldering

#### (1).IR Reflow soldering (JEDEC-STD-020 compliant)

One time soldering reflow is recommended within the condition of temperature and time profile shown below. Do not solder more than three times.

Profile item	Conditions
Preheat	
- Temperature Min (T Smin )	150°C
- Temperature Max (T Smax )	200°C
- Time (min to max) (ts)	90±30 sec
Soldering zone	
- Temperature (TL )	217°C
- Time (t L )	60 sec
Peak Temperature	260°C
Peak Temperature time	20 sec
Ramp-up rate	3°C / sec max.
Ramp-down rate from peak temperature	3~6°C / sec
Reflow times	≤3

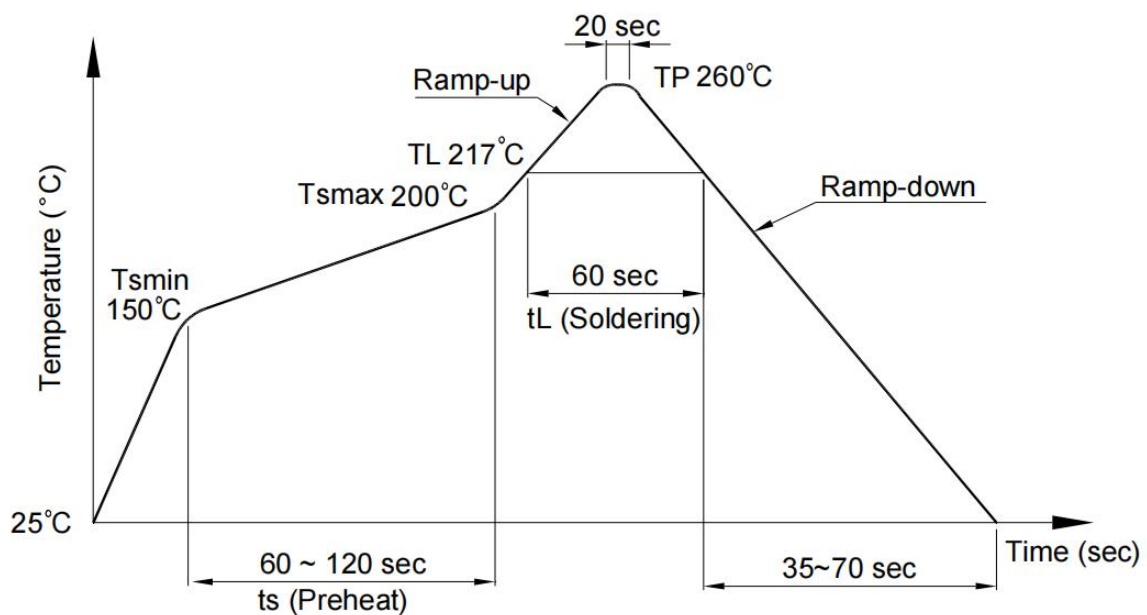

**(2).Wave soldering (JEDEC22 A111 compliant)**

One time soldering is recommended within the condition of temperature.

Temperature	260+0/-5°C
Time	10 sec
Preheat temperature	25 to 140°C
Preheat time	30 to 80 sec

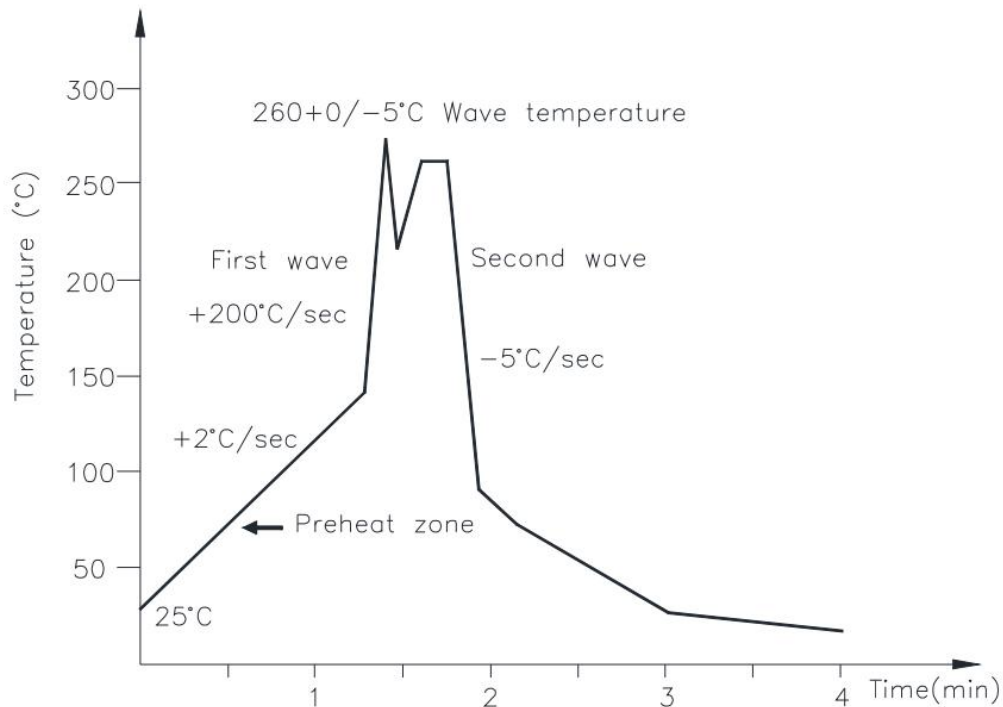

**(3).Hand soldering by soldering iron**

Allow single lead soldering in every single process. One time soldering is recommended.

Temperature	380+0/-5°C
Time	3 sec max

### 14. Characteristics Curve

Fig.1 Forward current vs Ambient temperature

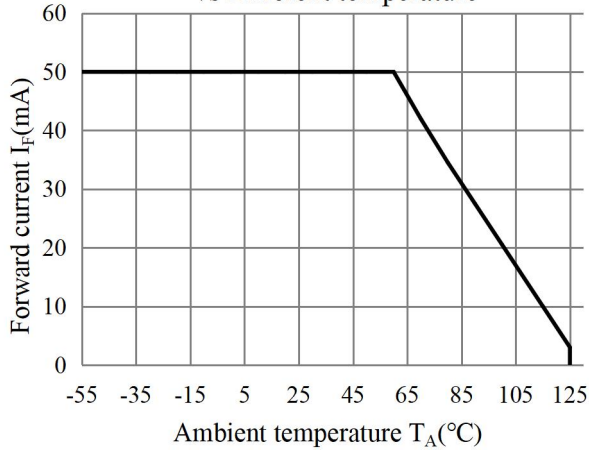

Fig.2 Collector Power Dissipation vs. Ambient temperature

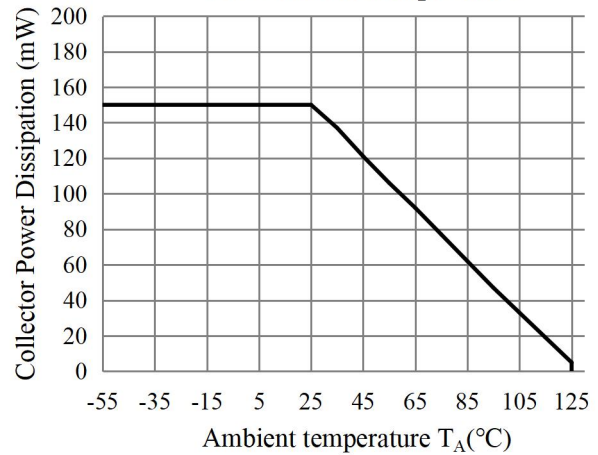

Fig.3 Forward Current vs. Forward Voltage

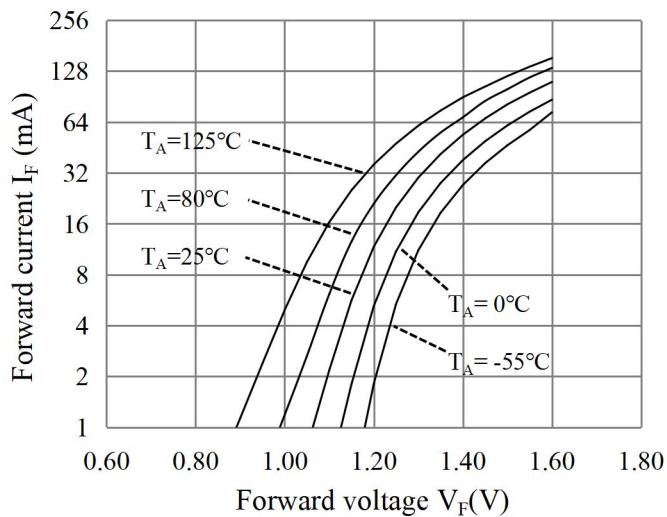

Fig.4 Collector-emitter Saturation Voltage vs. Forward Current

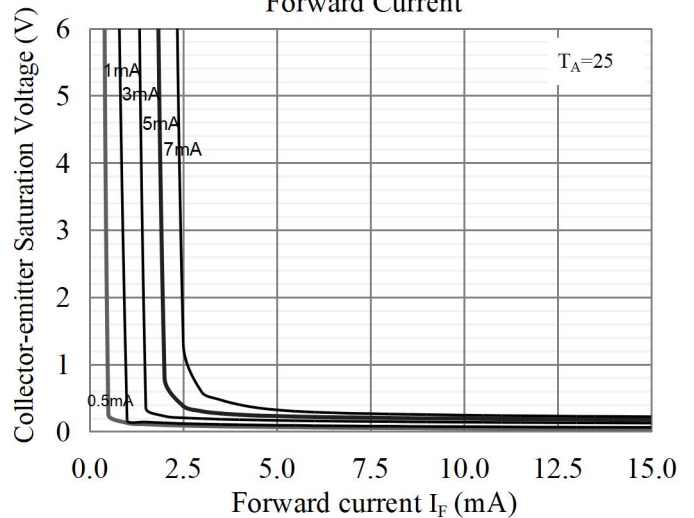

fig.5 Collector Current vs. Non-Saturated Collector Emitter Voltage

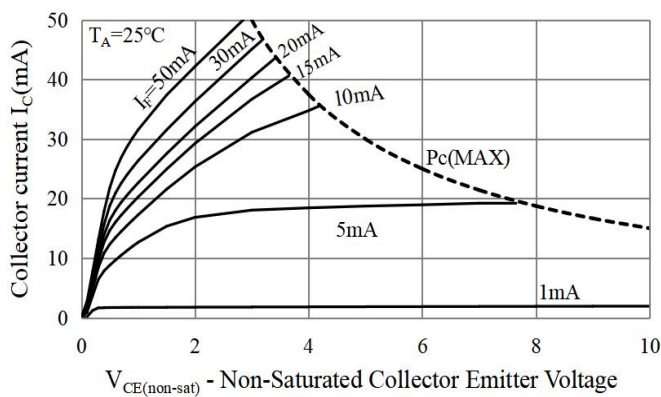

fig.6 Collector Current vs. Non-Saturated Collector Emitter Voltage

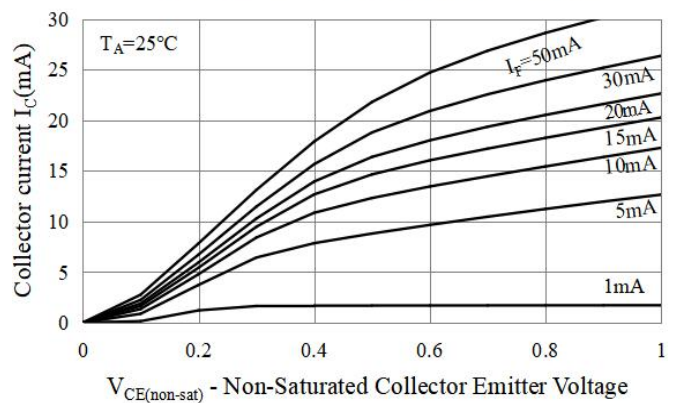

Fig.7 Relative Current Transfer Ratio vs. Ambient Temperature

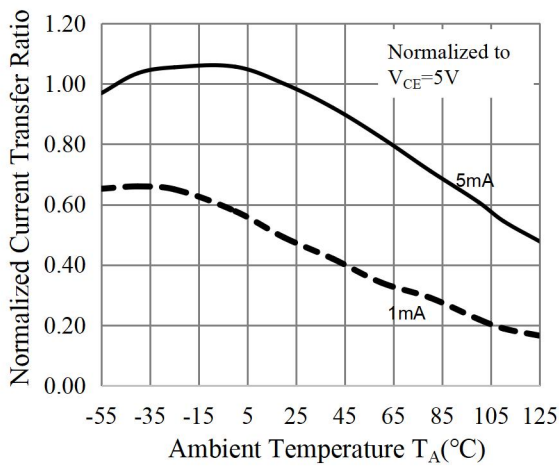

Fig.8 Relative Current Transfer Ratio vs. Ambient Temperature

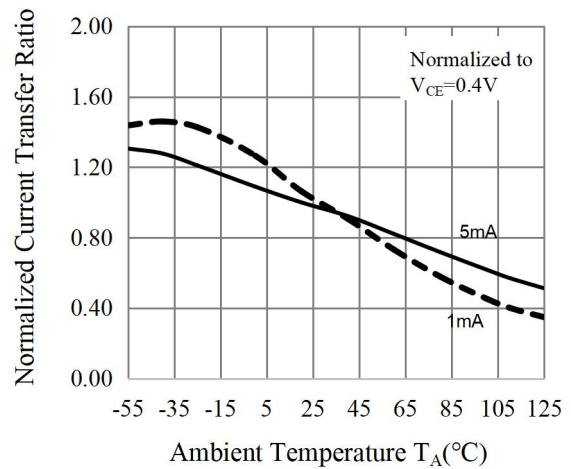

Fig.9 Forward Current vs. Current Transfer Ratio

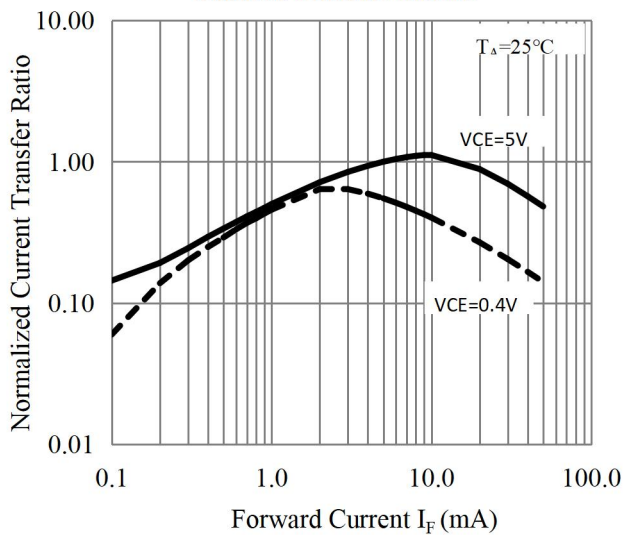

Fig.10 Collector Dark Current vs. Ambient Temperature

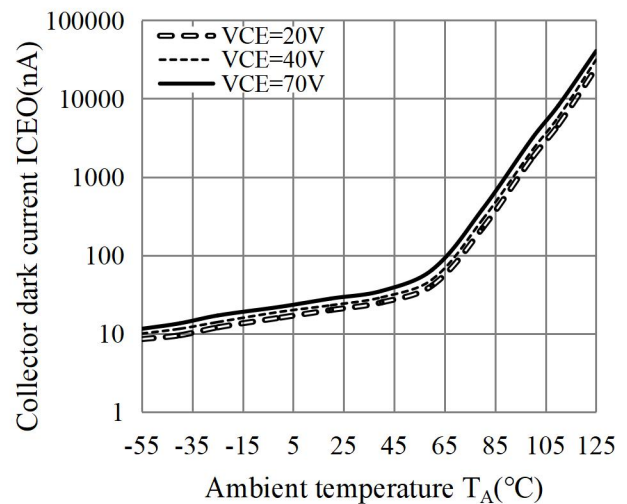

Fig.11 Collector-emitter Saturation Voltage vs. Ambient Temperature

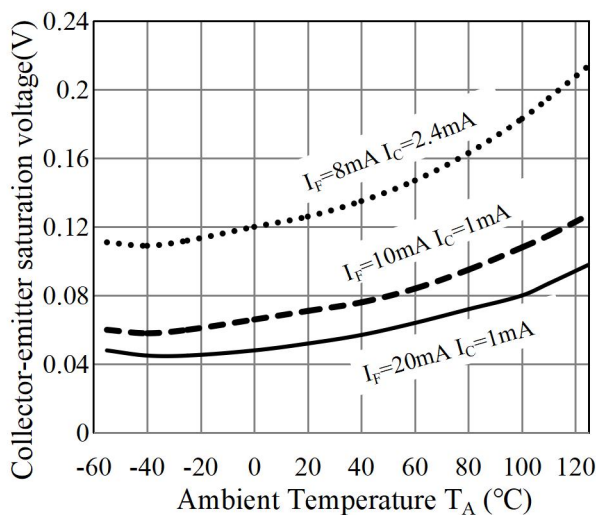

Fig.12 Switching Time vs. Load Resistance

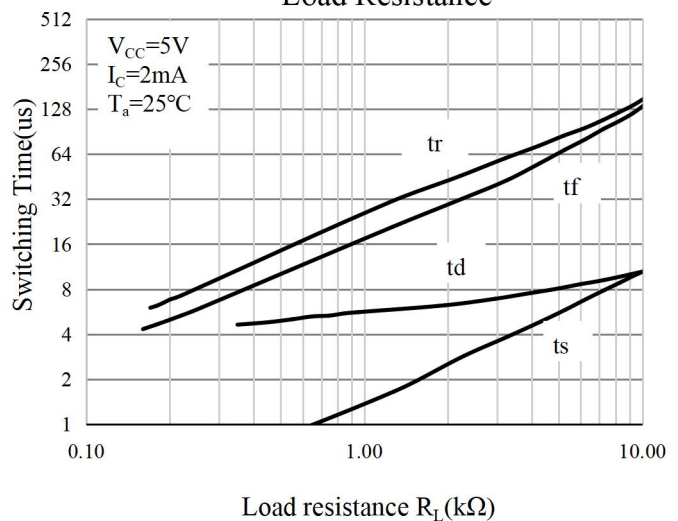

Fig.13 Respinse Time vs. Ambient temperature

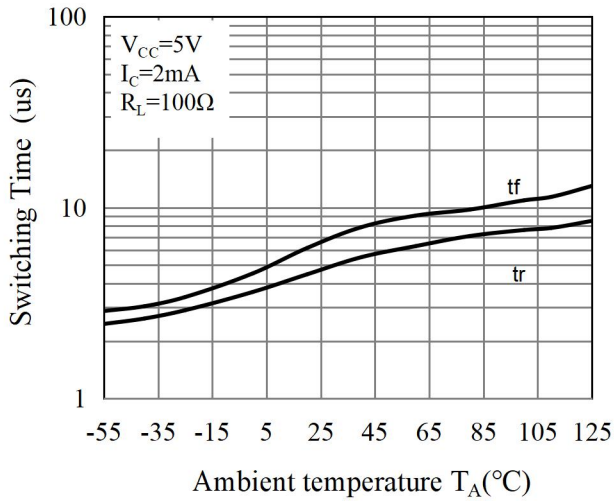
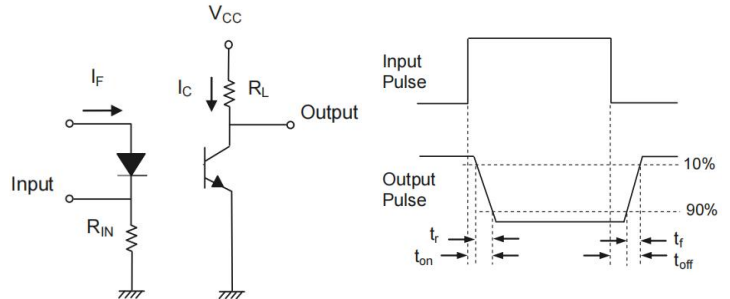

Fig.14 Switching Time Test Circuit & Waveforms



## 15.NOTES

1. Orient is continually improving the quality, reliability, function or design and Orient reserves the right to make changes without further notices.
2. The products shown in this publication are designed for the general use in electronic applications such as office automation equipment, communications devices, audio/visual equipment, electrical application and instrumentation.
3. For equipment/devices where high reliability or safety is required, such as space applications, nuclear power control equipment, medical equipment, etc, please contact our sales representatives.
4. When requiring a device for any "specific" application, please contact our sales in advice.
5. If there are any questions about the contents of this publication, please contact us at your convenience.
6. The contents described herein are subject to change without prior notice.
7. Immerge unit's body in solder paste is not recommended.